

NEW



ANALYTICAL INSTRUMENTS GROUP
25 years of technology



G.N.R. is glad to present the new METAL LAB PLUS, ideal solution for laboratory working station optical emission spectrometer. Following the success of the previous generation METAL LAB, worldwide acclaimed as one

of the best laboratory instrument for chemical alloy analysis, G.N.R. is now launching the new version with multi-CCD optics and newest technical solution and ergonomic design.

METAL LAB PLUS

METAL LAB PLUS

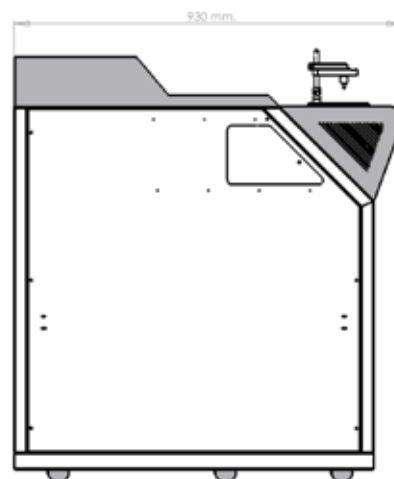
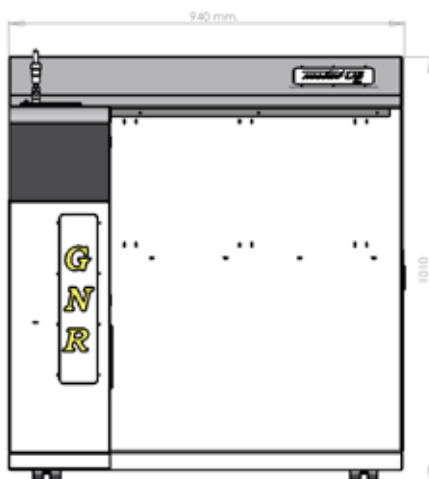

TECHNICAL DATA

Multi Optic System: Multi High Resolution Vacuum and Air CCD optical chambers system with up to 16 CCD solid state detectors depending on specific application.

Spectral field: wide spectral field from 130 to 900 nm. High luminosity holographic grating.

Source: Multi-frequency HEPS spark source. Excitation parameters fully controlled by computer.

Software: MLab software, operating in Windows environment is very easy to be used. The operator can really use all the spectrometer's functions. Some of the most important functions are listed: Analysis, Automatic standardization Printing and management of certificates, Determinations of alloys in accordance to international norms (UNI, ASTM, DIN, ...), Network linking and remote control, Autodiagnosis, SPC Statistical Process Control Charts (optional)

Personal Computer (optional): Intel Dual Core, 2 Gb Ram, 160 Gb HD 7.200 rpm, Combo DVD + DVD RW, Monitor 19 LCD, mouse, keyboard and HP deskjet printer

Power supply: 110/220 V AC 16 A 2,5 KW

Dimensions: D 93 x W 94 x H 101 cm

Weight: 160 Kg c.a.



GNR ANALYTICAL INSTRUMENTS GROUP

Sales Office:
G.N.R. S.r.l. - Via Torino, 7
28010 Agrate Conturbia (NO) - Italy
Tel. +39 0322 882911
Fax +39 0322 882930
E-mail: gnrcomm@gnr.it - gnrtch@gnr.it - www.gnr.it

Local Agent